

2023 MSM PRO STOCK 254 RULES

September 16th, 2023

NOTICE TO COMPETITORS - It is solely the competitors responsibility to read the information presented here in order to be informed as well as be in compliance with all aspects of the rules in this document.

1 **BODIES**

2004-17 ABC Five-Star bodies are to be installed just as specs suggest. That means 47" roof height and 4" body height. Will run 6.5" spoiler on ABC cars. NOTE: for rules regarding approved bodies and their installation please refer to the current **A-B-C rulebook (ver.9.0)**.

- Bodies will be standard fiberglass quarter panels, deck lid filler, hood, roof, and fenders.
- No Carbon Fiber
- Manufacturer's identification labels must be visible and not painted over.
- Body panels must be mounted as produced. No "pulled in" fenders, doors, quarter panels, etc.
- Body air ducts may only allow air into interior NOT exhaust it out.
- **The spoiler must have a 1/2" split in the center to accommodate the centerline template.**
- **Spoiler length will be measured on the back side and will be a maximum 60".**
- **Roof and rear window air deflectors are allowed. A maximum of 2 mounted parallel to each other with a maximum height of 1". Must have a minimum 1" gap at top of rear window to allow for template access.**

Complete ABC Body Rules at www.fivestarbodies.com

NOTE: For 2012 all bodies may run an approved Five Star "Lexan" rub rail.

NOTE (2) Hood and Trunk Lids: For 2012 the hood and trunk MUST be hinged to allow it to be flipped open but remain with the vehicle in the event the car needs to be towed from the track. Recommend Fivestar Universal Hinge Kit. This will align with rule 21.2.

- **Radiator shroud must pull air only from the original opening of the ABC nose. No pulling of air from the base of the shroud to the ground.**
- **Rocker panels must be ABC factory approved ONLY.**
- **NO Plastic or carbon fiber interior panels allowed.**
- **NO under body air deflectors or panning allowed**
- The duct work between the nose and the radiator may be no wider than 30" and may not be carbon fiber.
- No pulling of air for brake ducts anywhere other than the side of the radiator shroud or the nose ducts. Blower may be mounted to side of air box parallel to the ground. No ducting hoses facing straight down.
- The standard opening for the grill screen area, as approved for manufacturer's production,

must be maintained at all times. Only ABC manufacturer's standard mesh screen may be used for the radiator opening in the nose. Fivestar screen is 28" x 7.5". AR Body screen is 30" x 7.25".

- Tape may not be used on the grill screen

2003 and older Bodies – See “Appendix B”.

For 2015 the AR Bodies Muscle Car Body will be allowed. This body must be installed as per AR Body specifications and dimensions. See appendix “C” for body chart. These bodies will be closely monitored for any deviations from manufacture dimensions.

NOTE: There will be no weight break for this body package at this time but these bodies will be monitored and adjustments may be made with prior notification

2 WEIGHTS - TREAD WIDTH

Engine Options (2021 summary)

Option #1: **Conventional Engine (steel head): 2800 lb. w/7000 Chip @ 58% Left Side**

Option #2: **GM Sealed Crate Engine (w/660-MPST seal): 2750 lb. w/6400 Chip @ 58% Left Side**

Option #3: **Ford McGunegill MEP 425LM Sealed Crate Engine: 2775 lb. w/6400 Chip @ 58% Left Side**

Option #4: **Ford D347SR Sealed Crate Engine: 2775 lb. w/6400 Chip @ 58% Left Side**

Option #5: **Mopar ASA 75360 MPST Sealed Crate Engine: 2775 lb. w/6400 Chip @ 58% Left Side**

Option #6 **PASS legal “GM Sealed 604 Crate with NO Changes” 2775 lb. w/6400 Chip @ 58% Left Side**

Option #7 **PASS legal GM cam change 604 (cam, lifter, 1.6 rockers): 2825 w/6400 Chip @ 58% Left Side**

NOTE: **Maximum left side weight percentage for ALL cars will be 58% before, during and after event. Zero tolerance for any percentage infraction.**

NOTE: All non “MPST or 660 sealed” crates will be checked post-race in the event the car is a top finisher or has won lap money. This will be a mandatory requirement for any cars designated to go to tech for engine check and disassembly. Any car that has won lap money but drops out before finish will be required to remain in pits for tech inspection

until notified by tech officials of the requirement to come to tech or not.

There is NO penalty for a dry sump engine.

Cars with a 7000 (or less) RPM rev limiter are permitted a maximum **58% left side** weight.

Cars with a 6400 (or less) RPM rev limiter and an approved "crate engine" are permitted a maximum **58% left side** weight.

Cars must be full of fuel for all heat races and features. Fuel MUST be visible in the CLEAR fill AND vent tube.

Cars must be full of fuel for all heat races and features (regular or special events).

Maximum tread width is 66". minimum is 64". Tread width will be measured at ride height. This may involve pushing front end down to touch 3"ride height block prior to measurement. This procedure will compensate for camber where necessary.

All ballast must be painted white and the car number must also be painted on it.

No weight – or other material is to be placed lower than the bottom of the frame rails.

3 FRAME

2" x 3" fabricated steel tubing or larger.

RIDE HEIGHT – No formal ride height rule however body MUST meet 3" minimum height for nose and rocker panels. In addition ALL vertical heights MUST pass during pre-race inspection such as crank height and fuel cell. Measurements will be taken with the driver out.

Minimum wall thickness of .083".

Minimum wheelbase is 101" on either side. The left side wheelbase must be +/- 1" of right side Maximum wheelbase is 105" (as per ABC specs).

50 lbs. per inch short of 101".

4 ENGINES

CONVENTIONAL ENGINE (Option #1)

360 cu.in. Maximum (measured with volume pump or manually).
10.5:1 maximum compression (10.99 absolute checked with a whistler).
Measurement of whistler will be final.
Cast iron heads and cast iron BLOCK only.
No porting, polishing, blueprinting, acid porting, or reworking of any kind.
Multi angle valve jobs accepted.

Flat tappet camshaft only. NOTE: We will be modifying the rule to allow roller camshaft with a 25lb penalty

No mushroom lifters.

No aluminum rods.

Roller rockers allowed.

Must run air breather.

Any 2 or 4 barrel intake allowed.

The bowl and short turn on the intake side, below the valve seat, may be reworked in as far as the head bolt. Bowl blending below the valve seat on the exhaust side is limited to one inch.

Port matching allowed in maximum 1/2" "

Gasket matching allowed 1/2" in only on ports.

Bowl blend on intake and exhaust down 1/2" max below the valve seat.

Minimum crankshaft (center) height 10". GM crate engine will carry a 11" crank height minimum.

G.M. 2" setback. Ford and Mopar allowed additional 2" setback from front most cylinder centered with upper ball joint. Engine, not body, determines setback.

No Australian, New Zealand or other exotic heads allowed.

No Plastic, carbon fiber, or fabricated aluminum intakes or other unauthorized parts will be allowed

GM SEALED 604 CRATE ENGINE (Option #2)

Crate Engine Details:

- Must use Holley 650 carb 4150HP # 80541-1
- Carb will bolt directly to the intake using a maximum .065 gasket only. No spacer plate is allowed
- Carb must pass Petty Raceway No-Go gauges
- These engines are sealed at the intake manifold, cylinder head, front cover, and oil pan with special twist off bolt heads
- The fuel pump pushrod may be replaced with a COMP CAM P/N 4607
- Original timing cover and harmonic balancer must remain as produced
- Headers must be a 1 5/8" to a 1 3/4" stepped header with a 3" collector
- Maximum RPM limit is 6400.
- **Crate engines" will maintain a minimum crank height of 11"**.
- All "crate engines" must be approved by Petty Raceway officials and tagged for identity purposes before they can enter competition.

MCGUNEGILL FORD 425 LM SPEC/CRATE ENGINE (Option #3)

NOTE: McGunegill 425 LM "spec/crate engine" will be permitted. Engine must be purchased through McGunell Engine Performance (MEP www.mcgunegillengines.com). These engines are sealed by MEP and will be required to have registered seals on motors to compete.

FORD SEALED CRATE ENGINE D347SR (Option #4)

- D347SR is allowed, complete with Holly carburetor model 4150HP# 80541-1.**
- **Carburetor will bolt directly to the intake using a maximum .065" gasket only.**
- No spacer plate is allowed.**
- Carburetor must pass Petty Raceway No-Go gauges.**
- Headers must be 1 5/8" to a 1 3/4" stepped header with a 3" collector.**
- Maximum RPM is 6400.**

MOPAR ASA 75360 MPST SEALED CRATE ENGINE (Option #5)

- **MOPAR ASA75360 sealed “crate engine” (wet sump only permitted)**
- ☐ **Holley Carburetor model 45150HP # 8054-1 is allowed.**
- **Carburetor will bolt directly to the intake using a maximum .065” gasket only.**
- ☐ **No spacer plate is allowed.**
- ☐ **Carburetor must pass Petty Raceway No-Go gauges.**
- **Headers must be 1 5/8” to a 1 3/4” stepped header with a 3” collector.**
- ☐ **Maximum RPM is 6400**

PASS 604 Crate Engine with NO Changes Factory stock (Option #6)

This is a factory sealed crate engine package, complete from intake manifold, stamped steel valve covers with racing style breathers, and 8 quart dual kick-out circle track racing oil pan. The Fast Burn 400 engine has a 1053 forged steel crankshaft, aluminum heads with 2.00"/1.55" valves, hydraulic roller lifters, (400 HP at 5500 RPM - Torque 400 @ 4500 RPM) The base engine is a Fast Burn 350ci 385 horsepower, with the following parts:
P/N 10105123 4 bolt iron block – Must Remain Stock
P/N 14088533 1053 steel crankshaft – Must Remain Stock
P/N 10108688 PM rod – Must Remain Stock
P/N 10159436 High silicon aluminum piston – Must Remain Stock. NO “Eyebrowing” the pistons for clearance
P/N 10185071 Camshaft with hydraulic roller lifters – The camshaft may NOT be changed.
P/N 12551483 Stock Valve Spring. or **P/N 12625033 blue beehive springs**
P/N 88960604 8” stock harmonic balancer or **5.7min dia harmonic balancer**
P/N 12464298 Aluminum head – Must Remain Stock. You may cut the heads .010 for clean-up. Minimum 60cc.
P/N 12496822 High rise single plane intake manifold, P/N 12366573 Aluminum dual plane (no EGR) or P/N 12496820

Aluminum dual plane (w/ EGR)– Must Remain Stock. Competitors competing with the original Fastburn 385 (intake manifold p/n 12366573 or p/n 12496820) may update to Fastburn 400 (p/n 12496822).

No balancing, grinding, machining, porting ect.

P/N 25534354 Oil pan may be replaced with either of the following part #: CV1106LTRB or CTR-102. or 8 quart oil pan or Moroso parts #21319, #21315, and CP106KORB pan is permitted with matching p/u assembly and champ CP106KORB permitted and utilized in factory form without modifications. Carburetor: a Holley HP Series 4 brl. 650 Carburetor (p/n 80541-1 or -2) or

Carburetor: Holley HP Series 4 bbl. 650 Carburetor (p/n 80541-1 or -2) ONLY (Petty Raceway Gauge legal carb)

Carburetor MUST bolt directly to the intake using a maximum .065” gasket only. No spacer allowed.

PASS legal GM cam change 604 (cam, lifter, 1.6 rockers) (Option #7)

NOTE 1: No Plastic, carbon fiber, or fabricated aluminum intakes or other unauthorized parts will be allowed on any engine package.

NOTE 2: All crate engines will require a minimum crank height of 11”.

All 2bbl steel head engines will require a minimum crank height of 10”.

5 ELECTRICAL

Battery: Must be mounted securely outside of driver’s compartment. A dry cell battery will be MANDATORY.

Alternator: The alternator system when used must be working within specifications.

Starter: The self-starter must be operational. Car must be able to start under its own power.

5.2 A Master Shut-off Switch must be mounted in the middle of the car, such that the driver can reach the switch while belted in the car. The location must be accessible to safety workers outside of the car, regardless of how the car is sitting. It must be fluorescent orange to ease finding it during an emergency. Decals to be used with the switch to indicate OFF and On. May be mounted to cage or dash bars in center.

6 IGNITION

There will be TWO ignition systems approved. The first will consist of the MSD 6AL or 6ALN analog distributor system. The other approved ignition will be the Crane Cams Ignition part # 6000-6701.

Speedway 660 and MPST competitors may use their inventoried boxes. Visiting cars may use their existing ignition systems as long they are either of the two approved systems listed above.

Both ignition systems will consist of ONE ignition coil, ONE ignition box, and ONE mag pickup type distributor.

Both systems will require the ignition box to be mounted UP ON THE RIGHT SIDE OF THE DASH.

All ignition wires must be easily visible and traceable. The mag pickup wires must not be cut or spliced from the ignition box to the connector at the distributor. Mag wires must be separate from the rest of the ignition harness.

RPM limiter chips will be sealed in the MSD 6AL and 6ALN boxes.

The Crane Ignition part # 6000-6701 must be mounted so that the rpm limiter dials face the right side of the car. The dials will be sealed by tech officials during pre-race inspection.

NON-CRATE ENGINES WILL HAVE A 7000 RPM Limit.

CRATE ENGINE CARS WILL HAVE A 6400 RPM Limit.

For 2017 the tachometer may be functional for all heats and features. The tach wire will not be required to be disconnected

NOTE: The speedway has two MSD ignition boxes that may be rented if required. The cost is \$40 for the event. Harness extensions will also be available to move the box up on right side of the dash if necessary.

See Appendix "A" for ignition wiring diagrams (MSD shown - Crane similar)

For further assistance please contact Tech Director Wayne Smith wayne@pettyraceway.com

7 CARBURETOR

Holley 4412 500 CFM stock carburetor.

Choke horn may be removed with a square cut, no taper or bevel may be cut into the body of the carburetor.

Boosters may not be changed. Size and shape may not be altered. Height must be standard.

Venturi area must not be altered in any manner. Casting ring must not be removed.

No polishing, grinding, or drilling holes permitted in the body of the carburetor.

Base plate must not be altered in shape or size.

Stock butterflies must not be thinned or tapered. Idle holes may be drilled in

butterflies Screw ends may be cut even with shafts but screw heads must remain standard.

Throttle shaft must remain standard and must not be thinned or cut in any manner.

Power valves, and jets may be changed.

Carburetors must pass all Petty Raceway No-Go gauge tests

There must be two return springs on separate brackets. One spring to be forward mounted and one rearward mounted.

A positive throttle stop will be MANDATORY. This is to prevent a possible hung throttle. Throttle stop may be either firewall or carburetor mounted (i.e. Longacre Primary Throttle Stop bracket, Holley 2 BBL Item # 32732 and Holley 4 BBL Item # 32730).

ALL Crate Engine(s):

- **Must use box stock Holley 650 carburetor 4150HP # 80541-1**
- **Carburetor will bolt directly to the intake using a maximum .065 gasket only. No spacer plate allowed.**
- **Carburetor must pass all Petty Raceway No-Go gauge tests**

NOTE: Carburetor Inspection will be on a voluntary basis during the 200 pre-race inspection process.

8 WHEELS

Maximum ten inch measured bead seat to bead seat.
Steel wheels only.

Bleeder valves will be allowed

9 SHOCKS & SUSPENSION

One per wheel regardless of manufacturer

The following shock/suspension packages are approved for competition:

- **Coilover shock/spring with or without bump stops/bump spring (as per example)**
- **External bump stop kit-solid shaft and bump package (as per example)**
- **External shock with bump stop package-Coil spring only at control arm**
- **Travel indicators allowed on each package**



Sealed steel/aluminum shocks (non rebuildable) and rebuildable shocks will be permitted. Shocks with External adjusters will be allowed. EXTERNAL RESERVOIRS OR CANISTERS WILL BE PERMITTED.

For 2022 cars with MPST legal AFCO & QA1 shocks will be allowed a 50lb total weight break.

No travel limiting devices such as chains, cables, bolts, etc. subject to technical discretion. Type of springs including height and wire diameter is optional. Springs are magnetic steel only. Steel spindles only. No driver adjustments other than ONE adjuster for brakes.

10 CLUTCH

Any safe clutch and flywheel may be used.
Scatter shield mandatory with open clutch.

Minimum diameter of clutch discs is 5.5". Magnetic steel plates only (i.e. no carbon fiber)

11 REAR END

The maximum gear for all cars will be 5.88:1 gear. There will be no minimum gear rule. Built steel head engines MUST run a 7000 rpm limiter.

A solid spool type rear end only.

Differential oil coolers are permitted.

Drive axles must magnetic steel only. No other material allowed.

“Front Change” quick change rear ends will NOT be permitted.

Outboard solid drive flanges on rear end may be replaced with rubber drive plates only.

Lower trailing arms may be solid or have a rubber biscuit on either lower arm. The single panhardbar on the rear suspension will be solid with heim joints on both ends, solidly mounted to the frame on both sides. No titanium axles, bars, or arms. No Watts link or similar configurations.

The third link should be a single solid bar with one connecting point (heim joint) on each end which can be adapted to a single torque device between the two connecting points. The third link assembly unit must have no more than one bar, one single linear spring, or one bar, one linear spring and one neoprene or rubber biscuit, or one bar and no more than two biscuits. No “dual action”, “right foot”, “pull bars”, “two way” or similar assemblies. No gas or liquid pressure devices allowed. No shock, torque arm, 6th coils, extra bars, etc.

12 RADIATOR

Radiator must remain stock in appearance and remain in standard position.

Stock type water pump only.

Radiator dust screens permitted. No blocking of air flow from nose to radiator.

Radiator must include liquid over flow can (minimum capacity 1 liter) mounted ahead of engine firewall. Over flow vent must exit the vehicle at the base of the windshield.

No anti-freeze allowed in the cooling system. Water only.

No cool down units, pumps, exotic fans allowed. If you have to ask it's not legal.

13 TRANSMISSION

Any two, three or four speed manual with operating reverse. Gears not to exceed 4 forward gears. Must have at least 2 forward gears and 1 reverse gear in working order.

Clutchless (Bert type) transmissions are allowed as well as Jericos.

Must race 1:1 ratio.

No gear may be closer than 1.23 to 1. (i.e. 3rd gear in a four speed can't be any closer to 1.00 than 1.23)

No variable ratio transmissions.

No 5-speed transmissions.

14 TIRES

For 2022 the approved tire for competition will be the Hoosier 1070.

See competitor package for additional tire information

TIRE POLICY DETAILS (from competitor information package)

1. **No team is permitted to have tire softener in their possession or (anywhere in vehicles) on track grounds.**
2. **All tires not on the car must remain piled FLAT outside the trailers IN PLAIN VIEW of all other competitors AT ALL TIMES.**

15 BRAKES

Functional four-wheel brakes with a working caliper on each wheel are mandatory. Calipers may be made of steel, cast iron or aluminum only. Cast iron brake rotors only. They cannot be steel or cast iron faced aluminum. No carbon fiber material is allowed. Maximum four pistons per caliper. Maximum one caliper per wheel. Electronic wheel speed sensors or brake activators will not be permitted.

Brake fluid circulators permitted. Liquid or gas cooling not permitted.

No Blowers or air directional devices to include duct hoses are permitted to be directed at tires in any manner. All Blowers and/or ducting must be directed only to the brake rotors.

Wheel mounted cooling fans will be allowed.

16 NUMBERS

Numbers must be on the roof, readable from the right side of the car, and on both front doors, at least 18 inches high and three inches wide.

Must have a six inch number on the top passenger corner of the windshield, painted white. All numbers must be dark on a light background, or light on a dark background. No gold, silver, or trick numbers.

The driver will be notified of any numbers deemed difficult to score.

17 DRIVE SHAFT

Driveshaft material must be steel or aluminum only. No carbon fiber, titanium, etc.

Only a one piece driveshaft will be permitted.

Driveshaft must be painted white (or bare aluminum) and be surrounded by two 1/4" (minimum thickness) safety hoops.

18 EXHAUST

Mufflers are mandatory on all cars regardless of bottom or side exhaust exit. Recommended mufflers include but not limited to Howe 3002, 3005, 3006, 3015, 3018, 3044. A maximum decibel reading will not be enforced at this time but it is requested that teams choose a muffler that will provide a measure of noise limitation.

No stainless steel or carbon fiber headers, mufflers, pipes, etc are permitted. Exhaust may be turned down under car or exit out the right door. If exhaust exits under car, exit must point toward ground ahead of the rear axle. If the exhaust outlet exits through the right door it may not extend out past the door panel. Exhaust flange at door must not have sharp edges. **The bottom of the exhaust outlet is not to exceed twelve (12) inches from ground at exit.**

19 FUEL CELL

Maximum 22 U.S. gallons.
Must have at least 8" ground clearance.
Fuel cell must be mounted behind the rear end.

For 2017 an ATL or Fuel Safe FIA /SFI 32.1.certified bag type rubber bladder fuel will be MANDATORY.

Fuel Cell must be equipped with CLEAR fill AND vent hoses. Fuel must be visible before heats and feature.

An Oberg Fuel Line Safety Check Valve #SV-0828 (or equivalent) will be Mandatory. It must be installed in the fuel supply line close to the fuel tank.

No horse shoe or "U" shaped cells. The front side of cell is to be no closer than 11" to the back of the rear end tube.

20 FUEL

At this time there is no "spec" fuel identified.

21 DRIVER'S COMPARTMENT

All cars must have a safe roll cage, constructed of 1-3/4" o.d., .090 wall steel tubing. The base of the upright members must be solidly welded to the frame.

Cage must be reinforced by side-to-side members.

Four side bars on drivers side are mandatory.

All roll cages must be approved by technical inspector.

All roll bars within drivers reach must be padded.

Approved aluminum racing seat and four point harness properly mounted to the cage is mandatory.

Crotch belt is recommended.

Belts must be dated no more than two years old. Minimum date code on belts must be 2017

Minimum belt width of three inches.

All cars must have an approved window net, properly installed in the left front window opening and must have a quick release. No string type nets allowed.

All cars must be equipped with a quick release steering wheel. Center of the wheel must be padded.

Battery must be mounted securely outside of driver's compartment by a non-conductive cover.

22 BUMPER

Maximum 2" diameter pipe or tubing.

TOW HOOK/LOOP may be installed in both front and rear of car to allow for recovery vehicles to quickly lift cars and move them to the pit area. Recommended installation would be a steel cable and/or bracket attached to the frame rails or cage and accessible when the hood and/or trunk lid are opened.

23 COMMUNICATIONS

Any team using talking and/or listening devices **MUST** provide track officials with all their frequencies. Only 100, 400, and 800 MHZ frequencies allowed. NO 900 MHZ frequencies. All frequencies must be able to be monitored by official's multi-channel scanner with NO modification. All frequencies **MUST** be able to be monitored by track officials. No scrambling allowed.

A scanner (monitoring track officials) must be attached to a spotter with direct communications to the driver.

24 SCORING DEVICES

Transponders will be available at Speedway on raceday.

TRANSPONDER LOCATION

Transponder mounting bracket will be installed on the inside of the left rear frame rail.

The bracket must be mounted 12" from the rear edge of the axle tube to the center of the mounting bracket and the transponder must be vertical to the ground.

(See APPENDIX "D")

25 DRIVER PROTECTION

The use of head and/or neck restraint system is MANDATORY.

Aluminum or carbon fiber full containment seat is MANDATORY. Seat must be secured to the roll cage with a minimum of six (6) grade 8 fasteners.

A full face helmet with a minimum SNELL rating of SA or SAH 2010 will be MANDATORY. Helmets must accompany the vehicle at time of inspection.

The HANS device tether straps will be inspected. While not mandatory at this time, the __ straps are recommended to be replaced either every 5 years or in the case of hard impact then immediately.

Full fire suit in good condition is mandatory and must be used when ever the car is on the track. Fireproof shoes and gloves are MANDATORY.

An approved fire extinguisher dated for the current year must accompany car at all times. Fire extinguisher must be a minimum of 2.5lbs.

A fire suppression system is strongly recommended.

A full enclosure seat is strongly recommended.

5 point seat belt harness (minimum 3" wide) mandatory. 2 year maximum belt life

A fire extinguisher of a minimum 5 lb. must be clearly visible in the teams pit area. Extinguisher must display car number on the side.

26 MISCELLANEOUS

No electronic or manual traction devices.

No onboard wedge adjustments permitted.

Any new technology equipment must be approved by Petty Raceway before it can be used.

Track reserves the right to amend any rule with prior (fair) notice to competitors.

NO CARBON FIBRE PARTS ANYWHERE (unless otherwise specified).

NO TITANIUM or other exotic metals allowed. All drivetrain and suspension fasteners must be magnetic steel only

No digital gauges, or electronic monitoring computer devices capable of storing or transmitting information (except analog tach) are permitted. **Only Analog Stepper Motor electronic gauges allowed.**

Petty Raceway reserves the right to confiscate and retain any parts or components that are deemed to be non-conforming to the rules set forth in these pages. The decision of track management will be final.

APPENDIX "A": IGNITION WIRING DIAGRAMS (Crane Similar)

MSD 6AL Wiring Diagram

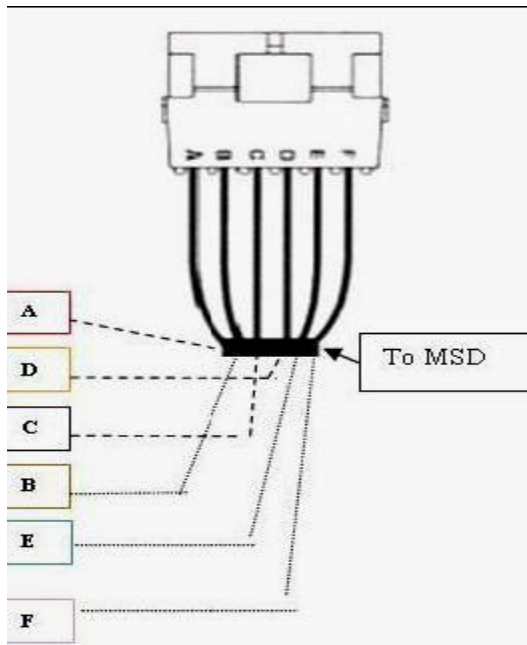
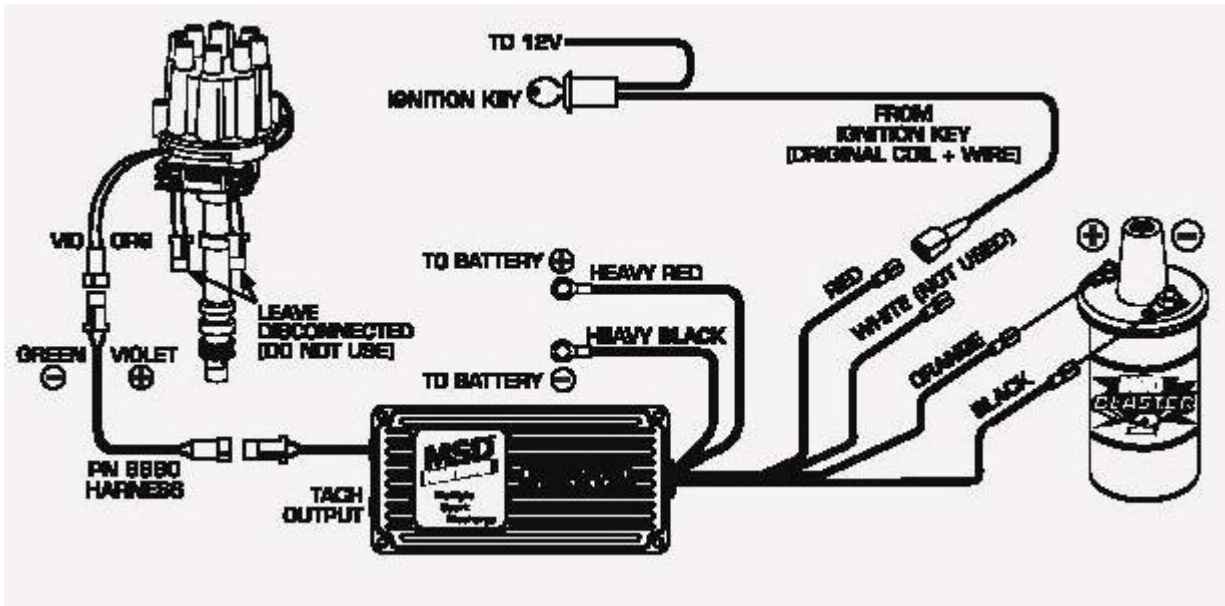
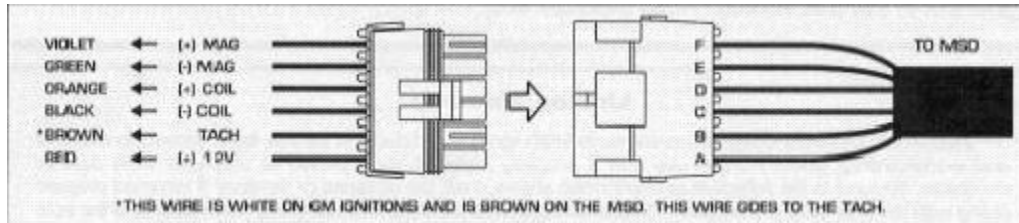

(A), (B), (C), (D), (E) and (F) to the 8170 Connector.
 (G) Maximum 36" (H) Maximum 12" (quick-connect plugs recommended)

APPENDIX "B" – 2003 and Older Bodies

2003 and older Bodies

All bodies must be stock appearance, steel, fiberglass or aluminum.

Bodies must be installed to meet ALL FiveStar dimensions and angles.

Bodies must meet FiveStar templates with slight (approx 1/2 -3/4") tolerance at the base of windows.

All vertical measurements will be made with **driver OUT of car**.

Roof height must be a minimum of 46". Measured 10" from the top of the windshield on center.

Max deck height will be 34.0" from the ground to the top of deck at base of spoiler (Dimension K).

With the roof height at 46" and the rear deck height at 34 1/2" the gap between the template and the rear deck will be no more than 3/4 " at the base of the rear window and taper in a straight line to 0 at the spoiler.

Template is expected to fit tight in all other areas.

Nose must fit nose template with hood on and must comply with Dimension A.

Rear deck lid must NOT be riveted to the body. Must be hinged or made easily removable.

Rear deck must not be dished or raked side to side. NOTE: The deck lid opening must be a minimum of 48" wide by 12" deep. This will allow access to fuel cell for safety and inspection.

You are allowed a 6.5" high, 60" wide rear spoiler, with no side boxing.

Rocker panel/skirt must run perpendicular to the ground. (I.e. straight up and down)

Hood must be minimum of 15 lb, if weight must be added it must be molded into the hood and centered.

Body and window panels must be braced sufficiently to prevent bowing at speed. Rear window brace MANDATORY.

No cut down fenders or rear bumper covers.

Body MUST have min 3.5" ground clearance at all points.

Must run rear window.

Passenger AND drivers side **VENT** windows are permitted. They are not to be longer than 12" from the bottom corner of the "A" pillar rearward. Rear of window must be 90 degrees straight up and not bowed out.

Floor plate must be a minimum of 1/8 inch thick metal.

A plate of 16 gauge metal approximately 15" x 30" must be mounted on driver's door between skin and roll cage.

All jack positioners on cars must be positioned flush with or hidden beneath the door skin.

Exterior rub rails will not be permitted.

Non-conforming body clause: Long quarter paneled (+3.0") cars will be permitted to run limited events provided they run a 5.0" x 60" spoiler.

ARP Monte Carlo (2002-2003) will be allowed to compete but must fit Fivestar roof template and measurements. Also ARP body must run 5" spoiler. If 2003-4 nose is run car will carry a 25lb penalty. If right side deck exceeds 5.0" car will carry additional 25lb penalty.

APPENDIX "C"

Muscle Car Body Dimension Sheet

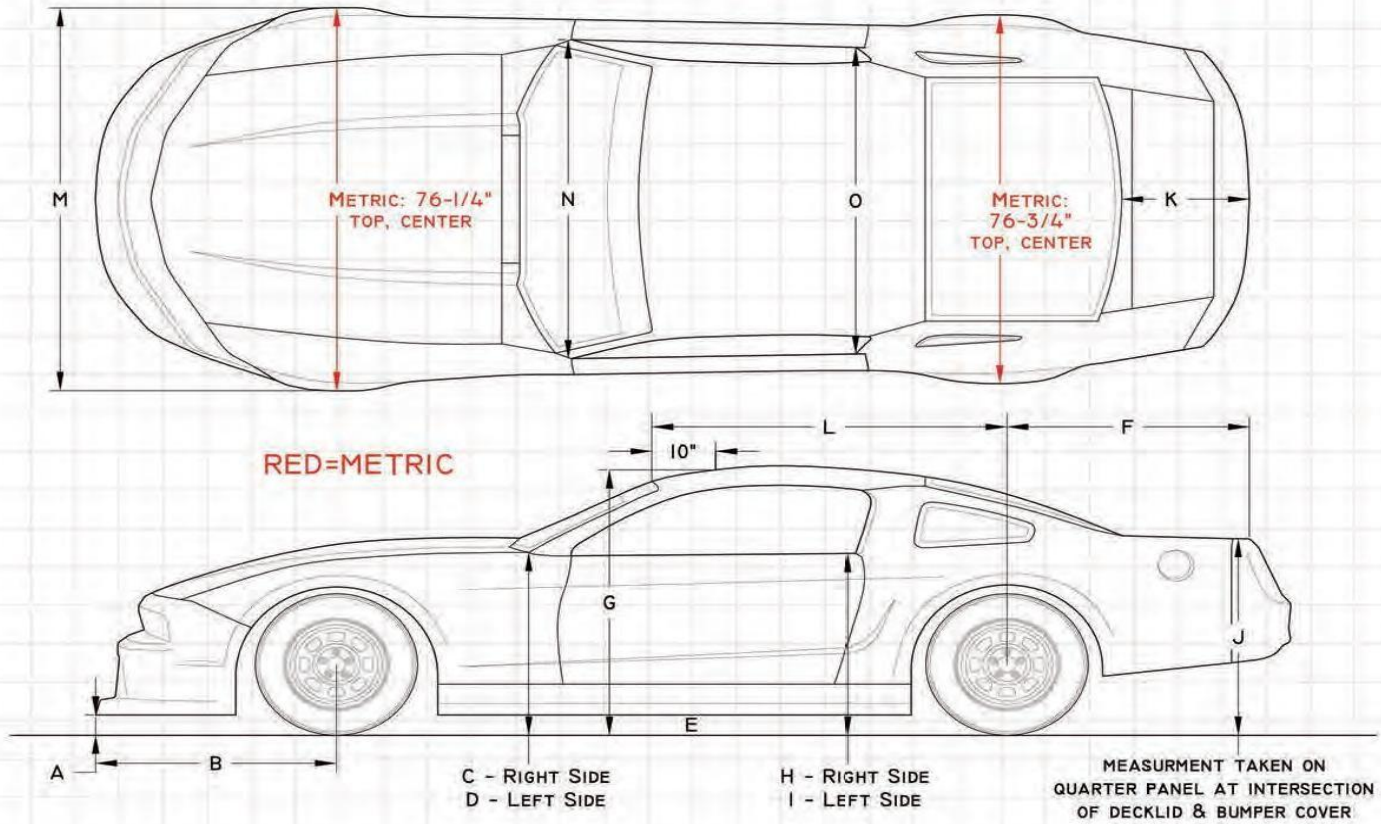

A.	NOSE HEIGHT (MIN): from ground to bottom of nose	4" 4 1/4"
B.	FRONT OVERHANG (MAX): on centerline	46 3/4"
C.	FENDER HEIGHT: RIGHT at front of A-post from ground	32 3/4" 32 1/2"
D.	FENDER HEIGHT: LEFT at front of A-post from ground	32 1/2"
E.	SIDE PANEL CLEARANCE (MIN): from ground	4"
F.	REAR OVERHANG (MAX): from base of spoiler at centerline to axle center	44 1/2"
G.	ROOF HEIGHT (MIN): 10" back from windshield, on centerline	48"
H.	DOOR HEIGHT: RIGHT at rear	33 1/4" 33"

I.	DOOR HEIGHT: LEFT at rear	33"
J.	QUARTER PANEL HEIGHT: at bumper cover/decklid intersection	35 1/2"
K.	REAR DECK: at center, from base of spoiler to rear window	21 1/2"
L.	FRONT OF ROOF TO CENTER OF REAR AXLE:	56"
M.	BODY WIDTH: at wheel wells	80" 78 1/2"
N.	DOOR TO DOOR WIDTH: FRONT at "A" post and inside edges of the doors	65 1/4" 66 1/2"
O.	DOOR TO DOOR WIDTH: REAR at "B" post and inside edges of the doors	63 1/4" 64 1/2"

APPENDIX "D"

Transponder Location

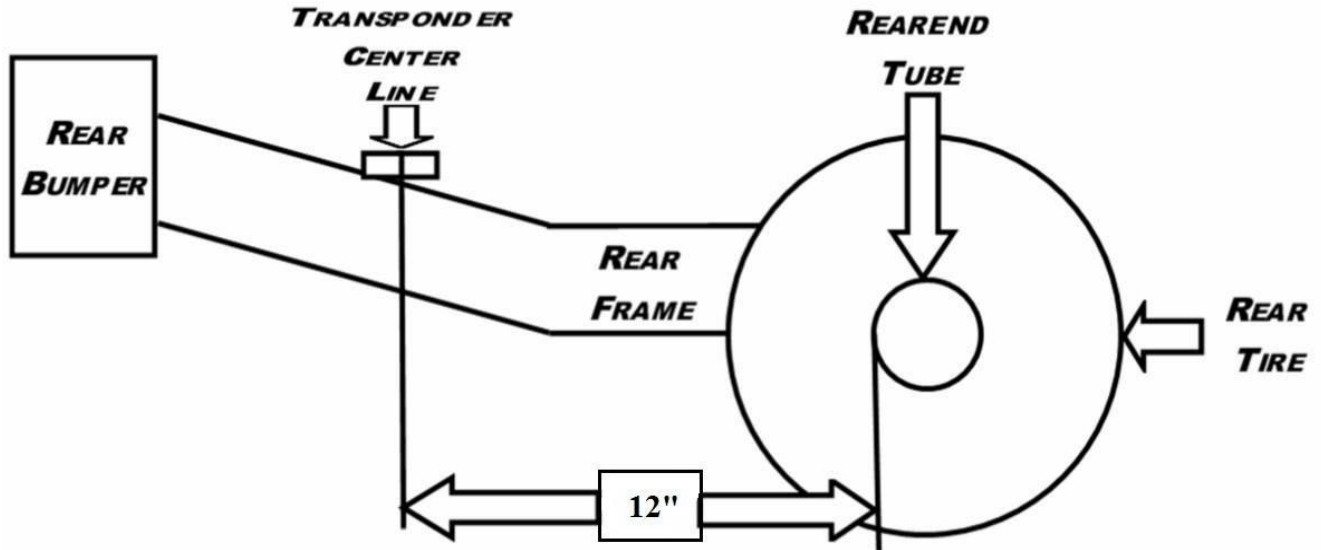

Transponder mounting bracket will be installed on the inside of the left rear frame rail. The bracket must be mounted 12" from the rear edge of the axle tube to the center of the mounting bracket and the transponder must be vertical to the ground.